

Date: August 8, 2007  
To: T10 Technical Committee  
From: Alvin Cox ([alvin.cox@seagate.com](mailto:alvin.cox@seagate.com))  
Subject: SAS-2 6Gbps PHY Electrical Specification

Abstract: The attached information defines the electrical requirements for 6 Gbps transmitter devices and receiver device. In addition, updates include reference transmitter and receiver device definitions to provide a means of determining if a channel is compliant and a cable specification section with requirements for 6Gbps usage. This proposal is a continuation of 07-063, at it ran out of revisions available.

The style of this proposal has changed to reflect SAS-2 requirements only. Due to the addition of spread spectrum clocking and different test procedures in some areas, it was determined better to list only SAS-2 requirements rather than try to maintain SAS-1.1 options in all areas.

#### Revision History:

r0: Initial posting that has changes documented up to but not including section 5.3.6.5.  
r1: Transmitter device specification completed, OOB transmitted signal requirements moved to the OOB transmitter output section 5.3.6.6, decimal representation changed from comma to period, changes documented through 5.3.6.6.

#### Reference proposals:

07-037 SAS-2 Common Mode Generation Specification [Witt, Bari]  
07-007 Proposed 6G SAS Phy Specs for EMI Reduction [Jenkins]  
07-001 Proposal for 6G SAS Phy Specification [Jenkins]  
06-419 SAS-2 Reference Transmitter and Receiver Specification Proposal [Witt]  
06-206 SAS-2 Data Eyes vs. De-Emphasis [Witt]  
06-053 Roadmap to SAS-2 Physical Layer Specification [Witt]  
06-052 Enhanced SFF-8470, SFF-8086 and SATA Cable at 6Gbps [Witt]  
06-049 Comparison of Equalization Schemes for 6Gbps SAS Channels [Caroselli]  
05-204 Towards a SAS-2 Physical Layer Specification [Witt]  
05-426 SAS-2 Cable Reach Objective and Crosstalk [Witt]  
05-425 SAS-2 Channel Model Simulations [Witt]  
05-342 SAS-2 Adaptive Equalizer Physical Layer Feasibility [Witt]  
05-341 Updated Test and Simulation Results in Support of SAS-2 [Witt]  
05-203 SAS-2 6Gbps Test Results [Witt]  
06-496 SAS-2 Electrical Specification Proposal [Witt]  
07-071 Return loss measurement methodology discussion [Bari]  
07-120 SAS-2 Transmitter De-Emphasis Measurement [Johnson, Bari]  
07-135 StatEye Tap Defined [Newman]  
07-236 SAS2-Statistical Confidence Levels of Test Results  
07-205 SAS-2: Improving a Jitter Definition [Hill]  
07-063 SAS-2 6Gbps PHY Electrical Specification [Cox]  
SAS-2r10 [Elliott]

New definitions:

**dBm (dB milliwatts):** The decibel ratio of a power value relative to one milliwatt. Hence, 20mW is equal to  $10 \cdot \log_{10}(20\text{mW}/1\text{mW}) = 13\text{dBm}$ . If this power were measured at a 50 ohm impedance level, 20mW would be equivalent to  $\sqrt{0.02\text{W} \cdot 50\text{ohms}} = 1\text{V}$  (equal to 60dBmV). However, at a 25 ohm impedance level (the ref impedance for common mode measurements), the same 20mW would be equivalent to  $\sqrt{0.02\text{W} \cdot 25\text{ohms}} = 0.707\text{V}$  (equal to 57dBmV).

**dBmV (dB millivolts):** The decibel ratio of an RMS voltage value relative to one millivolt. Hence 20 mV(rms) is equal to  $20 \cdot \log_{10}(20\text{mV}/1\text{mV}) = 26 \text{ dBmV}$ . Note that this does not depend on the impedance level.

**Decibel (dB):** One tenth of the common logarithm of the ratio of relative powers. The ratio of powers P1 and P2 in dB is  $10 \log_{10} (P1/P2)$ . If  $P1 = V1^2/R1$ ,  $P2 = V2^2/R2$ , and  $R1=R2$ , this is equivalent to  $20 \log_{10} (V1/V2)$ .

**Reference channel:** A set of s-parameters defining the electrical characteristics of a TxRx connection used as the basis for transmitter device and receiver device performance evaluation through mathematical modeling.

**Reference receiver device:** A set of parameters defining electrical performance characteristics to provide a set of minimum electrical performance requirements for a receiver device and that are also used in mathematical modeling to determine compliance of the TxRx connection or transmitter device.

**Reference transmitter device:** A set of parameters defining electrical performance characteristics of a transmitter device to be used in mathematical modeling to determine compliance of the TxRx connection.

## 5.3 Transmitter and receiver device electrical characteristics

### 5.3.1 Compliance points

Signal behavior at separable connectors requires compliance with signal characteristics defined by this standard only if the connectors are identified as compliance points by the supplier of the parts that contain the candidate compliance point.

Signal characteristics for compliance points are measured at physical positions called probe points in a test load (see 5.3.2). Measurements at the probe points in a test load approximate measurements at the compliance point in the actual TxRx connection. Some components in the test load may be de-embedded as described in B.4.

Return loss specifications are included in 6 Gbps signal characteristics. The receiver device return loss measurement points are at the IR and CR compliance points. Because the transmitter device return loss does not include the mated connector,  $IT_{RL}$  and  $CT_{RL}$  are unique locations for measurement locations for return loss while all other transmitter device characteristics are measured at the IT or CT probe points. The  $IT_{RL}$  or  $CT_{RL}$  compliance point also defines one end of the TxRx connection while the other end of the TxRx connection is located at the corresponding IR or CR compliance point. For the TxRx connection includes the characteristics of the mated connectors at both the transmitter device and receiver device ends.

Table 55 lists the compliance points.

**Table 55 — Compliance points**

Compliance point	Type	Description
IT	intra-enclosure (i.e., internal)	The signal from a transmitter device (see 3.1.279), as measured at probe points in a test load attached with an internal connector.
$IT_{RL}$	intra-enclosure (i.e., internal)	The location of a transmitter device (see 3.1.279) where the return loss is measured and where the TxRx connection begins. This location is at the transmitter device side of the internal connector with a test load attach or TxRx connection attached with an internal connector.
IR	intra-enclosure (i.e., internal)	The signal going to a receiver device (see 3.1.178), as measured at probe points in a test load attached with an internal connector.
CT	inter-enclosure (i.e., cabinet)	The signal from a transmitter device, as measured at probe points in a test load attached with an external connector.
$CT_{RL}$	inter-enclosure (i.e., cabinet)	The location of a transmitter device (see 3.1.279) where the return loss is measured and where the TxRx connection begins. This location is at the transmitter device side of the external connector with a test load or TxRx connection attached with an external connector.
CR	inter-enclosure (i.e., cabinet)	The signal going to a receiver device, as measured at probe points in a test load attached with an external connector.

Figure 98 shows the locations of the CT and CR compliance points using a SAS 4x or Mini SAS 4x cable assembly, and shows how two of the compliance points are tested using test loads (see 5.3.2).

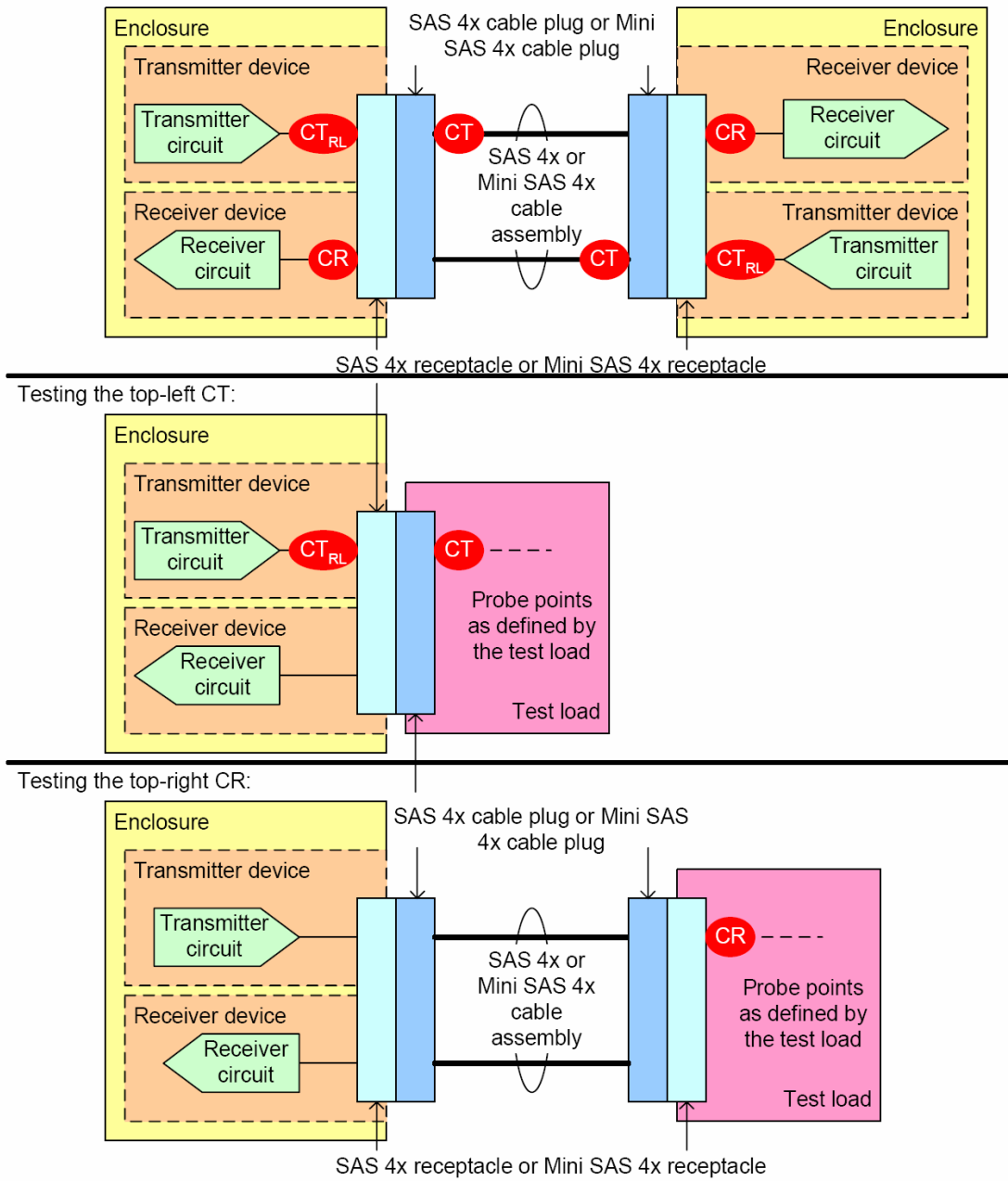
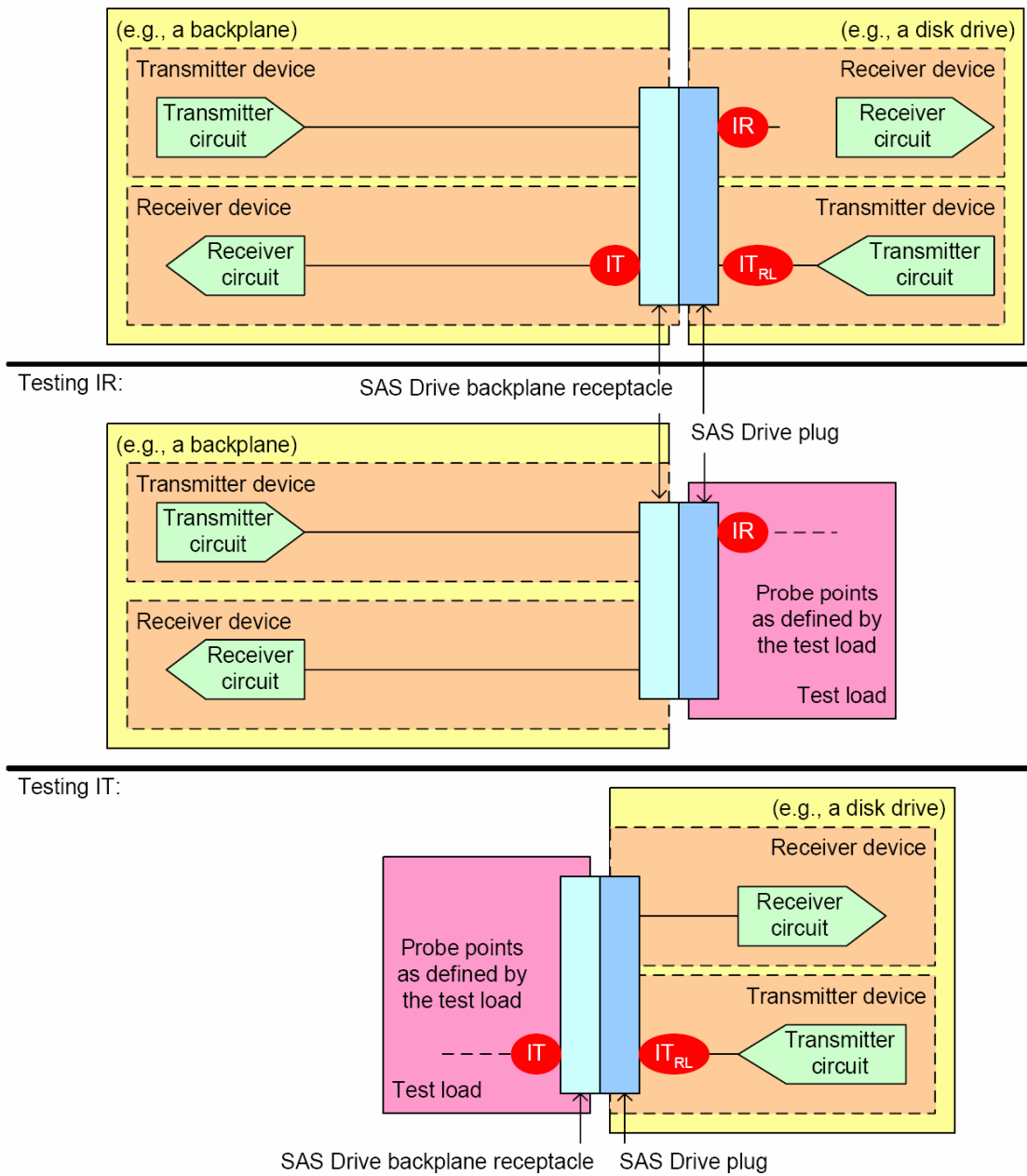


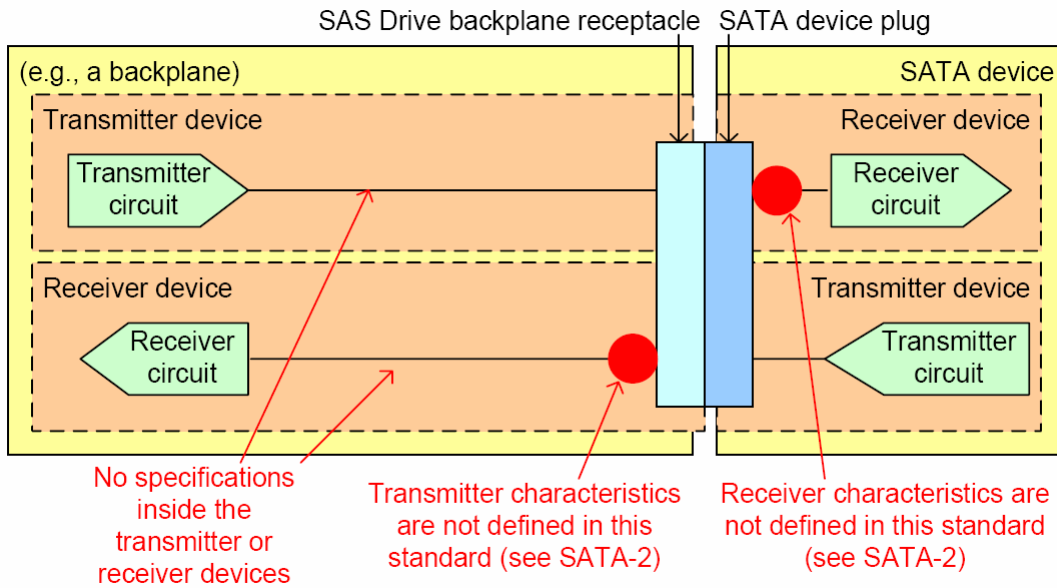
Figure 98 — SAS 4x and Mini SAS 4x cable assembly CT and CR compliance points

Figure 99 shows the locations of the IT and IR compliance points using a backplane with a SAS Drive backplane receptacle (see 5.2.3.2.1.3) that is not using SATA, and shows how the compliance points are tested using test loads (see 5.3.2).



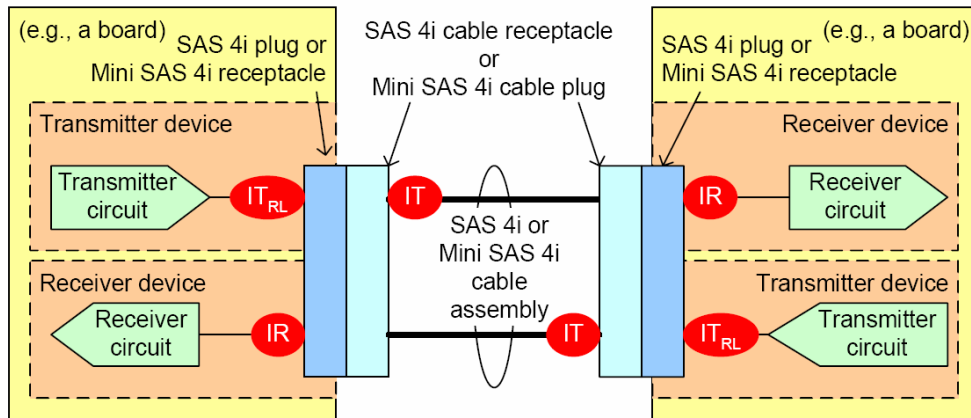
**Figure 99 — Backplane IT and IR compliance points**

If the backplane supports SATA, there are no IT or IR compliance points. SATA defines the signal characteristics that the SATA phy delivers and that the SAS backplane is required to deliver to the SATA device, as shown in figure 100.

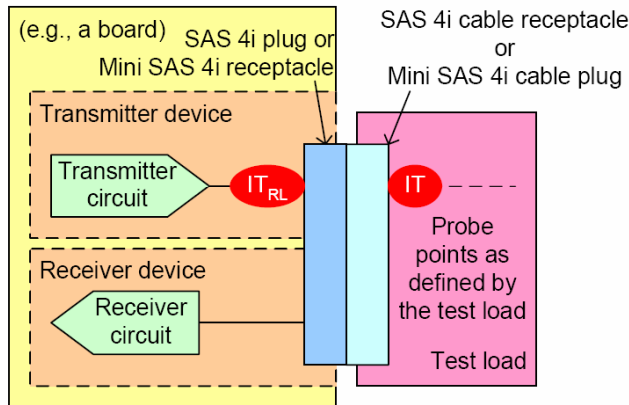


**Figure 100 — Backplane compliance points with SATA phy attached**

Figure 101 shows the locations of the IT and IR compliance points using a SAS 4i or Mini SAS 4i cable assembly, and shows how two of the compliance points are tested using test loads (see 5.3.2).



Testing the top-left IT:



Testing the top-right IR:

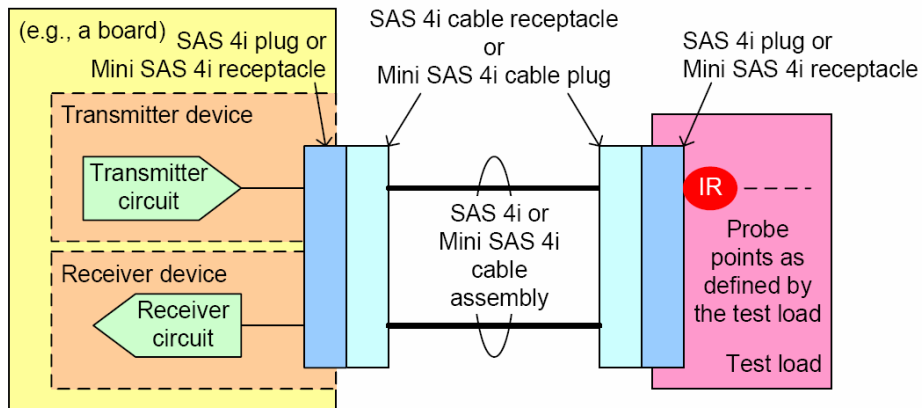


Figure 101 — SAS 4i and Mini SAS 4i cable assembly IT and IR compliance points

Figure 102 shows the locations of the IT and IR compliance points using a SAS 4i cable and a backplane, where the backplane is not attached to a SATA device, and shows how two of the compliance points are tested using test loads (see 5.3.2).

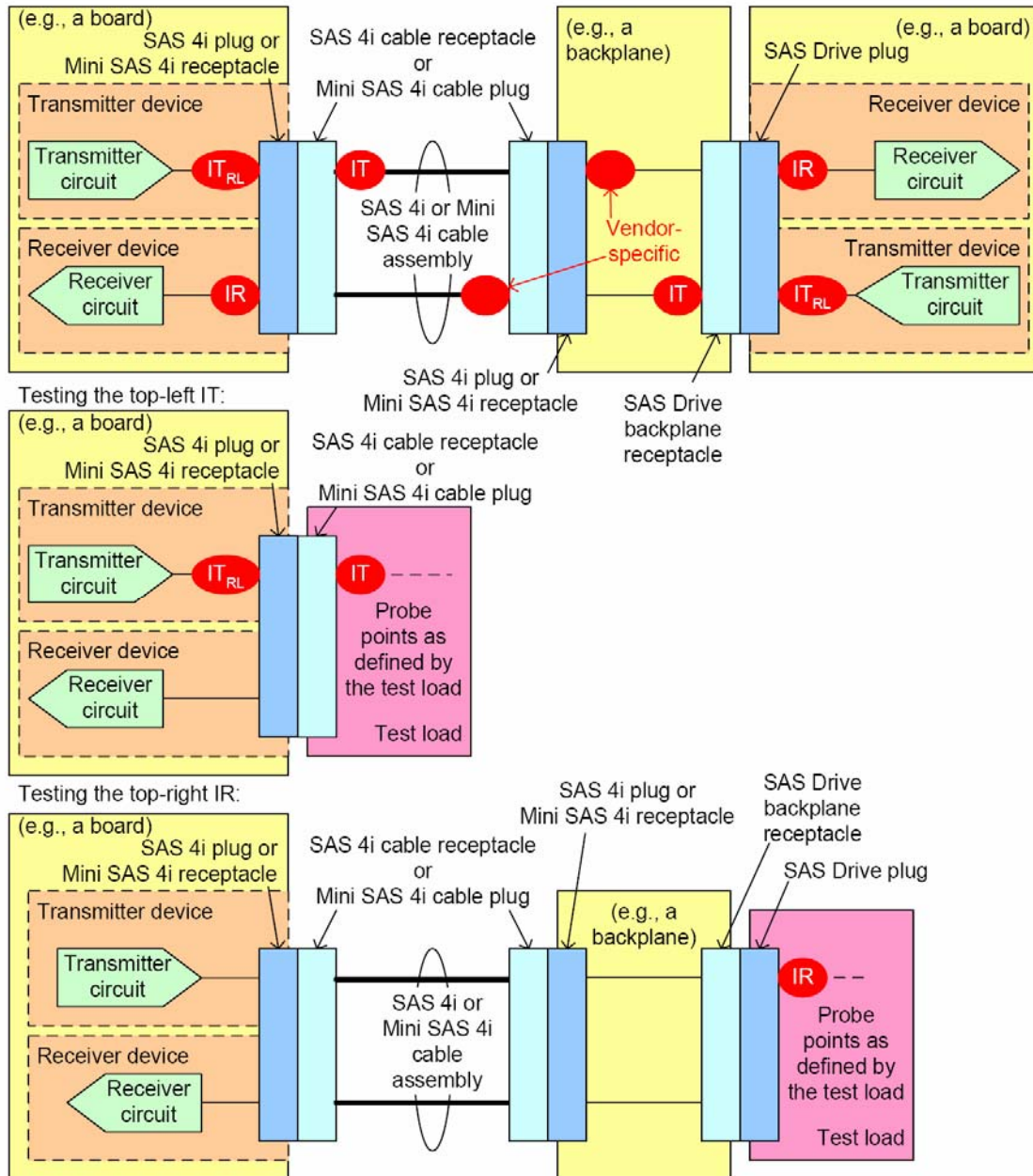
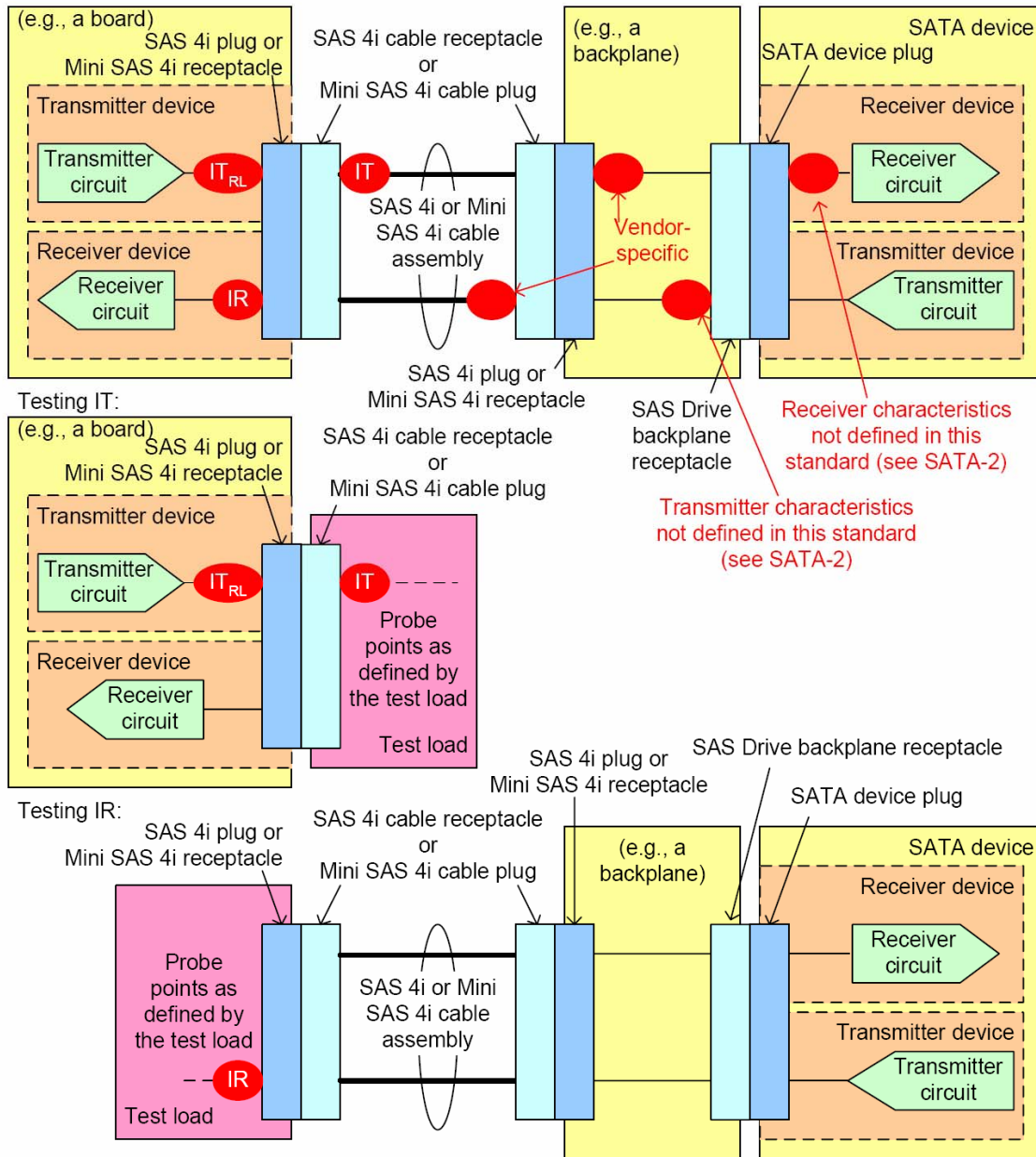


Figure 102 — SAS 4i and Mini SAS 4i cable and backplane IT and IR compliance points

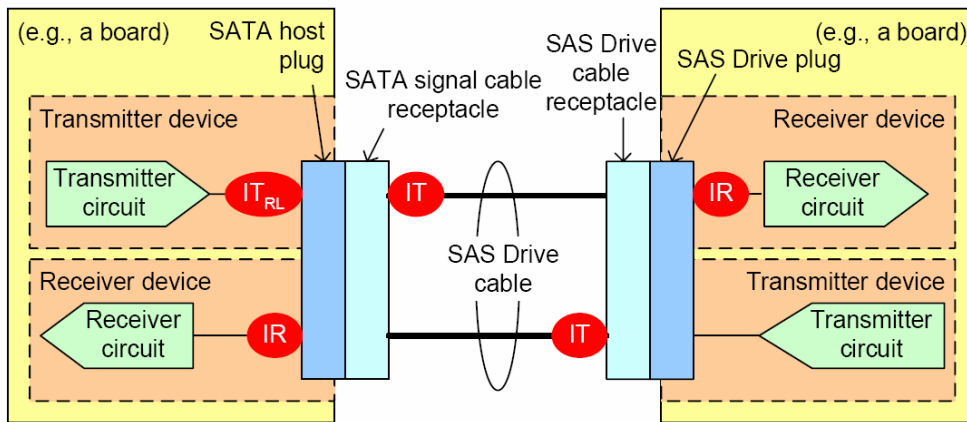


Figure 103 shows the locations of the IT and IR compliance points using a SAS 4i cable and a backplane, where the backplane supports being attached to a SATA device. There are no IT and IR compliance points at the SAS Drive backplane receptacle connector when a SATA device is attached; SATA defines the signal characteristics that the SATA device delivers and that the SAS backplane is required to deliver to the SATA device. There are compliance points at the SAS 4i connector, however.

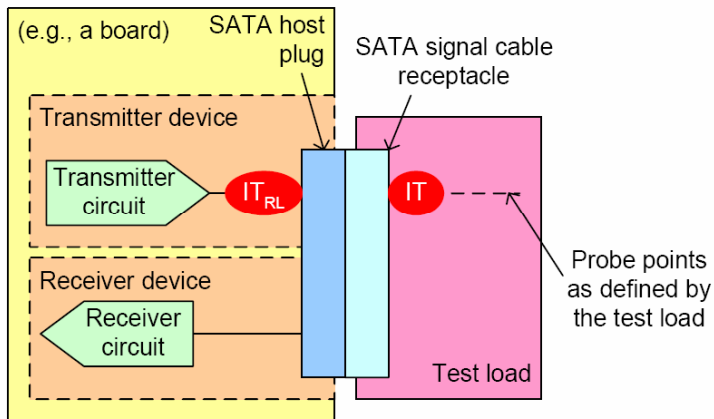


**Figure 103 — Internal cable and backplane IT and IR compliance points with SATA device attached**

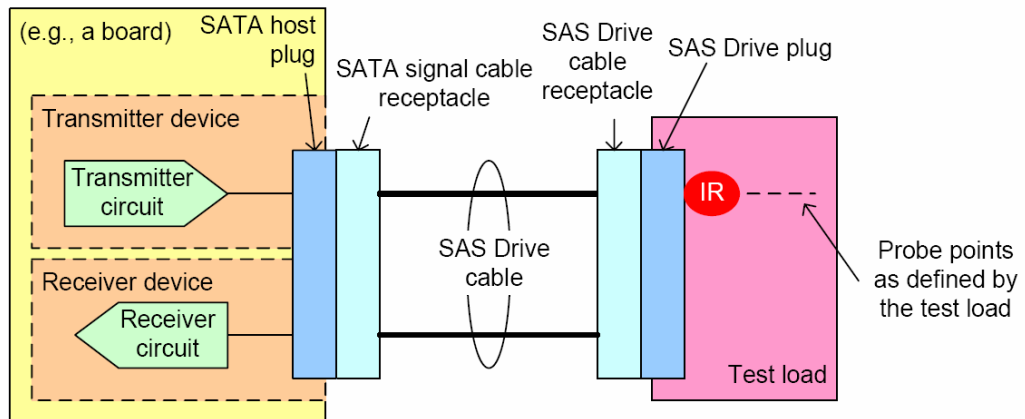
Figure 104 shows the locations of the IT and IR compliance points using an internal cable. It also shows how two of the compliance points are tested using test loads (see 5.3.2).



Testing the top-left  $IT$ :



Testing the top-right  $IR$ :



**Figure 104 — Internal cable IT and IR compliance points**

## 5.3.2 Test loads

### 5.3.2.1 Test loads overview

For 1.5 and 3 Gbps devices, a test load methodology is used for the specification of transmitter device signal output characteristics (see 5.3.6.2 and 5.3.6.3) and delivered signal characteristics (see 5.3.7.2). This methodology specifies the signal as measured at specified probe points in specified test loads.

The test loads used by the methodology are:

- a) zero-length test load (see 5.3.2.2): used for testing transmitter device compliance points and receiver device compliance points;
- b) transmitter compliance transfer function (TCTF) test load (see 5.3.2.3): used for testing transmitter device compliance points; and
- c) low-loss TCTF test load (see 5.3.2.3): used for testing transmitter device compliance points when SATA devices using Gen2i levels (see SATA-2) are supported and the SAS receiver device does not support the signal levels received through a full TCTF test load (see 5.3.2.3).

For 6 Gbps devices, the zero-length test load (see 5.3.2.2) is used but the transmitter compliance transfer function test load (TCTF) is not used for measuring the transmitter device signal characteristics. Instead, the delivered signal is determined by simulation methods (see 5.x.x.x) with the reference transmitter test load (see 5.3.2.5). The specified probe points within the zero-length test load do not apply to return loss measurements. If SATA devices are supported, see SATA specifications regarding Gen3 transmitter device and receiver device requirements.

Physical positions denoted as probe points identify the position in the test load where the signal properties are measured, but do not imply that physical probing is used for the measurement. Physical probing may be disruptive to the signal and should not be used unless verified to be non-disruptive.

### 5.3.2.2 Zero-length test load

**This section is being updated by proposal T10/07-304r0 SAS-2 Zero-Length Test Load Section**

### 5.3.2.3 TCTF test load

**No changes**

### 5.3.2.4 Low-loss TCTF test load

**No changes**

### 5.3.2.5 Reference Transmitter Test Load

For 6 Gbps simulation testing, the reference transmitter test load is described by the Touchstone (S-Parameter) model available from the T10 web site, proposal 07-193, SAS 2.0 Transmitter Test Load. This information is used with simulation methodology to determine transmitter delivered signal compliance. The specific simulation program used is beyond the scope of this specification. An example simulation file used with StatEye is available as proposal 07-xxx, (title). This simulation file includes the reference transmitter device, reference transmitter test load, and reference receiver device parameters already entered into the file to help develop the simulation process.

### 5.3.3 General electrical characteristics

Each TxRx connection shall support a bit error ratio (BER) that is less than  $10^{-12}$  (i.e., fewer than one bit error per  $10^{12}$  bits). The parameters specified in this standard support meeting this requirement under all conditions including the minimum input and output amplitude levels.

For 1.5 and 3 Gbps applications, each TxRx connection shall be designed such that its loss characteristics are less than:

- a) the loss of the TCTF test load plus ISI at 3 Gbps (see figure 108 in 5.3.2.3) over the frequency range of 50 MHz to 3 000 MHz; or
- b) the loss of the low-loss TCTF test load plus ISI at 3 Gbps (see figure 110 in 5.3.2.4) over the frequency range of 50 MHz to 3 000 MHz, if the system supports SATA devices using Gen2i levels (see SATA-2) but the receiver device does not support SATA Gen2i levels through the TCTF test load.

Each TxRx connection shall meet the delivered signal specifications in table 58 (see 5.3.7.2).

~~NOTE 17 – A TxRx connection is constructed from multiple components. It is possible that a TxRx connection does not meet the delivered signal requirements of table 58 (see 5.3.7.2) when the combined losses and noise introduced by those components is considered, even if each individual component is compliant with the requirements of this standard. Such a TxRx connection is not compliant with this standard.~~

For external cable assemblies, these electrical requirements are consistent with using good quality passive cable assemblies constructed with shielded twinaxial cable with 24 gauge solid wire up to 6 meters in length.

For 6 Gbps applications, the TxRx connection shall support a bit error ratio (BER) that is less than  $10^{-15}$  (i.e., fewer than one bit error per  $10^{15}$  bits) based on the results using StatEye (see [www.stateye.org](http://www.stateye.org)) or an equivalent simulation, with data input from s-parameter measurements of the TxRx connection, the specified reference transmitter device, and the specified reference receiver device. The specific simulation program used is beyond the scope of this specification. Simulations typically do not include all aspects of noise that may degrade the received signal quality. The support of a BER that is less than  $10^{-15}$  by simulation should yield an actual BER that is less than  $10^{-12}$ . For external Mini SAS 4x cable assemblies, these electrical requirements are consistent with using good quality passive cable assemblies constructed with shielded twinaxial cable with 24 gauge solid wire up to 10 meters in length.

Each TxRx connection segment shall comply with the impedance requirements detailed in 5.2.6 for the conductive material from which they are formed. An equalizer network, if present, shall be considered part of the TxRx connection.

TxRx connections shall be applied only to homogenous ground applications (e.g., between devices within an enclosure or rack, or between enclosures interconnected by a common ground return or ground plane).

Table 56 defines the general electrical characteristics.

**Table 56 — General electrical characteristics**

Characteristic	Units	1.5 Gbps (i.e., G1)	3 Gbps (i.e., G2)	6 Gbps (i.e., G3)
Physical link rate (nominal)	MBps	150	300	600
Bit rate (nominal)	Mbaud	1 500	3 000	6 000
Unit interval (UI)(nominal)	ps	666.667	333.333	166.667
Differential TxRx connection impedance (nominal)	ohm	100		
Maximum A.C. coupling capacitor <sup>a</sup>	pF	12		
Maximum noise during OOB idle time <sup>b</sup>	mV(P-P)	120		
<p>a. The coupling capacitor value for A.C. coupled transmit and receive pairs. A.C. coupling requirements for transmitter devices are described in 5.3.6.1. A.C. coupling requirements for receiver devices are described in 5.3.7.1.</p> <p>b. With a measurement bandwidth of 1.5 times the highest supported baud rate (e.g., 9.0 GHz for 6 Gbps), no signal level during the idle time shall exceed the specified maximum differential amplitude.</p>				

Table 57 defines the transmitter device general electrical characteristics.

**Table 57 — General transmitter device electrical characteristics**

Characteristic	Units	1.5 Gbps	3 Gbps	6 Gbps
Physical link rate long-term stability at IT and CT	ppm	±100		
Physical link rate SSC modulation at IT and CT	ppm	See table 66 and table 67 in 5.3.8.2		
Maximum transmitter device transients <sup>a</sup>	V	±1.2		
<b>Transmitter device source termination:</b>				
Differential impedance <sup>d</sup>	ohm	60 min/115 max		See 5.3.6.5.2
Maximum differential impedance imbalance <sup>b, c</sup>	ohm	5		See 5.3.6.5.2
Common-mode impedance <sup>b</sup>	ohm	15 min/40 max		See 5.3.6.5.2
<p><sup>a</sup> See 5.3.4 for transient test circuits and conditions.</p> <p><sup>b</sup> All transmitter device termination measurements are made through mated connector pairs.</p> <p><sup>c</sup> The difference in measured impedance to SIGNAL GROUND on the plus and minus terminals on the interconnect, transmitter device, or receiver device, with a differential test signal applied to those terminals.</p>				

Table 58 defines the transmitter device general electrical characteristics.

**Table 58 — General receiver device electrical characteristics**

Characteristic	Units	1.5 Gbps	3 Gbps	6 Gbps
Physical link rate long-term tolerance at IR if SATA is not supported	ppm	±100		
Physical link rate long-term tolerance at IR if SATA is supported	ppm	±350		
Physical link rate SSC modulation tolerance at IR and CR	ppm	See table 68 in 5.3.8.3		
Maximum receiver device transients <sup>a</sup>	V	±1.2		
Minimum Receiver A.C. common-mode voltage tolerance V <sub>CM</sub> <sup>b</sup>	mV(P-P)	150		
Receiver A.C. common-mode frequency tolerance range F <sub>CM</sub> <sup>b</sup>	MHz	2 to 200		
<b>Receiver device termination:</b>				
Differential impedance <sup>c, d, e</sup>	ohm	100 ± 15		See 5.3.7.x
Maximum differential impedance imbalance <sup>c, d, e, f</sup>	ohm	5		See 5.3.7.x
Maximum receiver termination time constant <sup>c, d, e</sup>	ps	150	100	N/A
Common-mode impedance <sup>c, d</sup>	ohm	20 min/40 max		See 5.3.7.x
<p><sup>a</sup> See 5.3.4 for transient test circuits and conditions.</p> <p><sup>b</sup> Receiver devices shall tolerate sinusoidal common-mode noise components within the peak-to-peak amplitude (V<sub>CM</sub>) and the frequency range (F<sub>CM</sub>).</p> <p><sup>c</sup> All receiver device termination measurements are made through mated connector pairs.</p> <p><sup>d</sup> The receiver device termination impedance specification applies to all receiver devices in a TxRx connection and covers all time points between the connector nearest the receiver device, the receiver device, and the transmission line terminator. This measurement shall be made from that connector.</p> <p><sup>e</sup> At the time point corresponding to the connection of the receiver device to the transmission line, the input capacitance of the receiver device and its connection to the transmission line may cause the measured impedance to fall below the minimum impedances specified in this table. With impedance measured using amplitude in units of ρ (i.e., the reflection coefficient, a dimensionless unit) and duration in units of time, the area of the impedance dip caused by this capacitance is the receiver termination time constant. The receiver termination time constant shall not be greater than the values shown in this table.</p> <p>An approximate value for the receiver termination time constant is given by the product of the amplitude of the dip in units of ρ and the width of the dip in units of time, as measured at the half amplitude point. The amplitude is defined as the difference in the reflection coefficient between the reflection coefficient at the nominal impedance and the reflection coefficient at the minimum impedance point.</p> <p>The value of the receiver device excess input capacitance is given by the following equation:</p> $C = \frac{\text{receiver termination time constant}}{(R_0 \parallel R_R)}$ <p>where (R<sub>0</sub>    R<sub>R</sub>) is the parallel combination of the transmission line characteristic impedance and termination resistance at the receiver device.</p> <p><sup>f</sup> The difference in measured impedance to SIGNAL GROUND on the plus and minus terminals on the interconnect, transmitter device, or receiver device, with a differential test signal applied to those terminals.</p>				

### 5.3.4 Transmitter and receiver device transients

**No changes.**

### 5.3.5 Eye masks

#### 5.3.5.1 Eye masks overview and jitter transfer function

The eye masks shown in this subclause shall be interpreted as graphical representations of the voltage and time limits of the signal. The eye mask boundaries define the eye contour of the  $10^{-12}$  jitter population at all signal levels. Current equivalent time sampling oscilloscope technology is not practical for measuring compliance to this eye contour. See MJSQ for methods that are suitable for verifying compliance to these eye masks. For 6 Gbps receiver device eye masks, simulations are used to approximate the eye diagram after application of receiver equalization rather than direct measurement of the signal at the IR and CR compliance points.

With the possible presence of Spread Spectrum Clocking (SSC), the application of a single pole high-pass frequency-weighting function that progressively attenuates jitter at 20 dB/decade below a frequency of  $((\text{bit rate}) / 1667)$  does not provide separation of the SSC component from the actual jitter and thus may overstate the jitter value. To differentiate between allowable timing variation and jitter, the following frequency-weighting function shall be applied to the signal at the compliance point when determining the eye mask. The jitter measuring device shall comply with the JTF specification below. The reference clock characteristics are controlled by the resulting jitter transfer function (JTF) characteristics obtained by taking the time difference between the PLL output (the reference clock) and the data stream sourced to the PLL. The PLL CLTF -3 dB corner frequency, and other adjustable CLTF parameters such as peaking, are determined by the value required to meet the requirements of the JTF.

The JTF shall have the following characteristics for an encoded D24.3 pattern (11001100110011001100). This is a test pattern that has clock-like characteristics and a transition density of 0.5.

- 1) The -3 dB corner frequency of the JTF shall be 2.6 MHz +/- 0.5 MHz.
- 2) The magnitude peaking of the JTF shall be 3.5 dB maximum.
- 3) The attenuation at 30 KHz +/-1% shall be 72 dB to 75 dB.

The JTF -3dB corner frequency and the magnitude peaking requirements shall be measured with sinusoidal PJ applied, with a peak-to-peak amplitude of 0.3 UI +/-10%. The relative attenuation at 30 KHz shall be measured with sinusoidal phase (time) modulation applied, with a peak-to-peak amplitude of 20.8 ns +/-10%.

### 5.3.5.2 Transmitter device eye mask

Figure 114 describes the eye mask used for testing the signal output of the transmitter device at IT, CT, IR, and CR for 1.5 and 3 Gbps. For 6 Gbps, the eye mask applies at IT and CT. For IR and CR, it applies after simulation of the reference receiver equalization (see 5.x.x.x). For all cases, this eye mask applies to jitter after the application of the JTF (see 5.3.5.1).

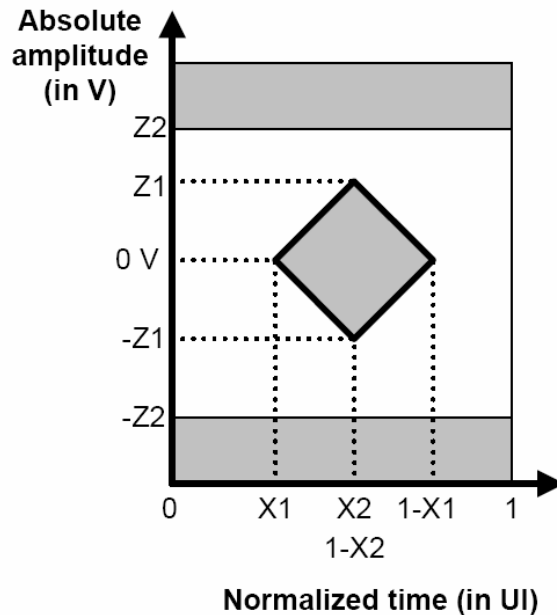


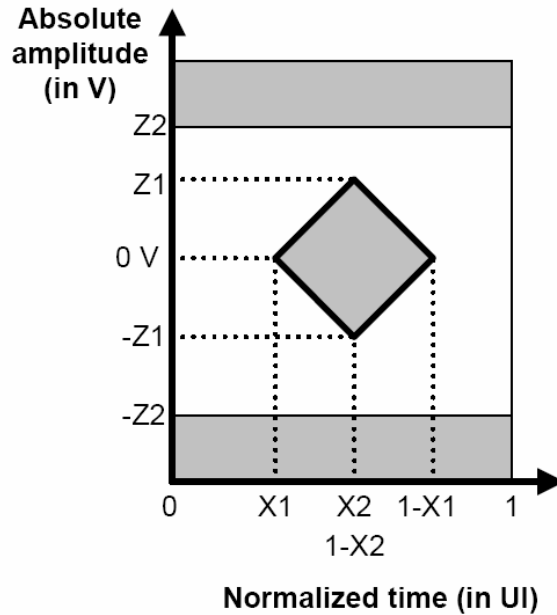
Figure 114 — Transmitter device eye mask

Verifying compliance with the limits represented by the transmitter device eye mask should be done with reverse channel traffic present in order that the effects of crosstalk are taken into account.

### 5.3.5.3 Receiver device eye mask

For 1.5 and 3 Gbps, Figure 115 describes the eye mask used for testing the signal delivered to the receiver device at IR and CR. For 6 Gbps, the eye mask at IR and CR applies after simulation of the reference receiver equalization (see 5.x.x.x). For all cases, this eye mask applies to jitter after the simulation of the JTF (see 5.3.5.1). This requirement accounts for the low frequency tracking properties and response time of the CDRs in receiver devices.





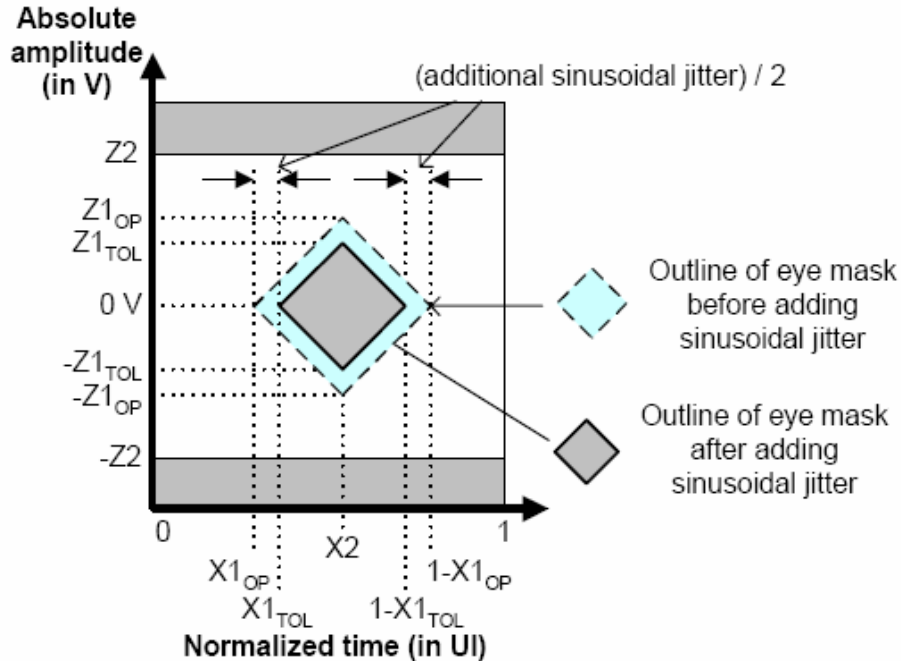
**Figure 115 — Receiver device eye mask**

Verifying compliance with the limits represented by the receiver device eye mask should be done with reverse channel traffic present in order that the effects of crosstalk are taken into account.

#### 5.3.5.4 Receiver device jitter tolerance eye mask

Figure 116 describes the eye mask used to test the jitter tolerance of the receiver device at IR and CR. Figure 116 shall be constructed using the following values:

- a) X2 and Z2 shall be the values for the delivered signal listed in table 62 (see 5.3.7.2);
- b) X1OP shall be half the value of TJ for maximum delivered jitter listed in table 63 (see 5.3.7.3); and
- c) X1TOL shall be half the value of TJ for receiver device jitter tolerance listed in table 64 (see 5.3.7.4), for applied sinusoidal jitter frequencies above  $((\text{bit rate}) / 1\ 667)$ .



**Figure 116 — Deriving a receiver device jitter tolerance eye mask**

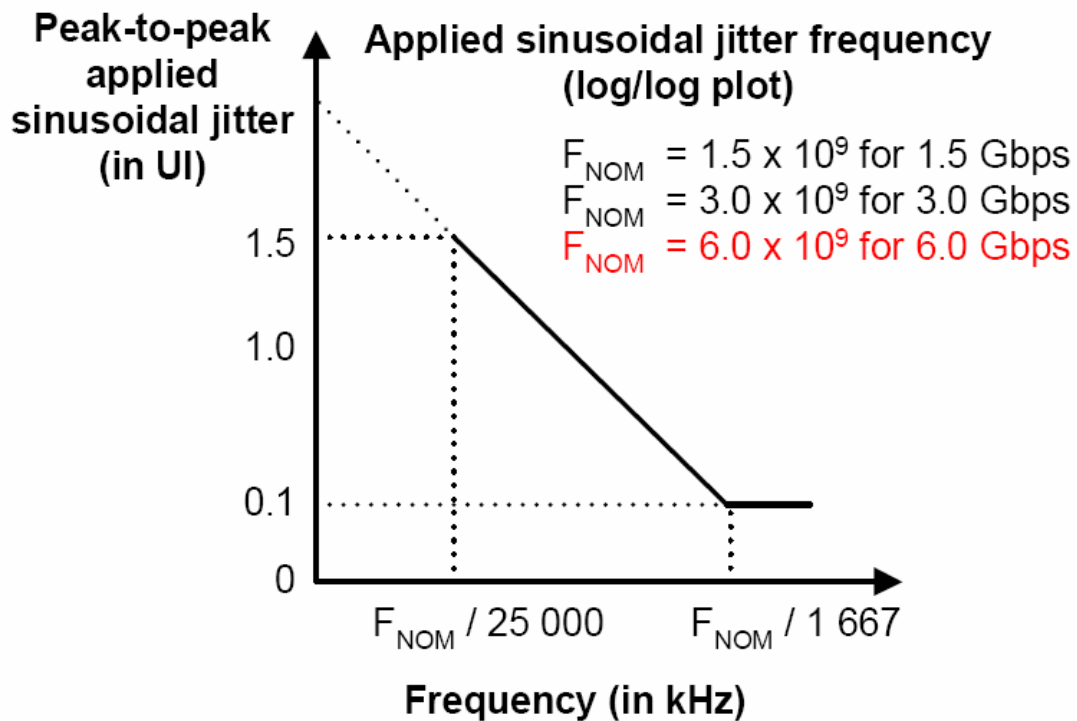
The leading and trailing edge slopes of the receiver device eye mask in figure 115 (see 5.3.5.3) shall be preserved. As a result, the amplitude value of Z1 is less than that given for the delivered signal in table 62 (see 5.3.7.2), and Z1<sub>TOL</sub> and Z1<sub>OP</sub> shall be defined from those slopes by the following equation:

$$Z1_{TOL} = Z1_{OP} \times \frac{X2 - \left(\frac{ASJ}{2}\right) - X1_{OP}}{X2 - X1_{OP}}$$

where:

- Z1<sub>TOL</sub> is the value for Z1 to be used for the receiver device jitter tolerance eye mask
- Z1<sub>OP</sub> is the Z1 value for the delivered signal in table 62
- X1<sub>OP</sub> is the X1 value for the delivered signal in table 62
- X2 is the X2 value for the delivered signal in table 62
- ASJ is the additional sinusoidal jitter defined in figure 117

The X1 points in the receiver device jitter tolerance eye mask (see figure 116) are greater than the X1 points in the receiver device eye mask (see figure 115) due to the addition of sinusoidal jitter.



**Figure 117 — Applied sinusoidal jitter**

CJTPAT shall be used for all jitter testing unless otherwise specified. Annex A defines the required pattern on the physical link and provides information regarding special considerations for running disparity (see 6.2) and scrambling (see 7.6).

### 5.3.6 Transmitter device characteristics

#### 5.3.6.1 Transmitter device characteristics overview

A.C. coupling requirements for transmitter devices are as follows:

- transmitter devices using inter-enclosure TxRx connections (i.e., attached to CT compliance points) shall be A.C. coupled to the interconnect through a transmission network;
- transmitter devices using intra-enclosure TxRx connections (i.e., attached to IT compliance points) that support SATA shall be A.C. coupled to the interconnect through a transmission network; and
- transmitter devices using intra-enclosure TxRx connections (i.e., attached to IT compliance points) that do not support SATA may be A.C. or D.C. coupled.

Transmitter devices may or may not incorporate pre-emphasis (i.e., de-emphasis) and other forms of compensation. The transmitter device shall use the same settings (e.g., pre-emphasis and voltage swing) with both the zero-length test load and the appropriate TCTF test load **or reference transmitter test load**.

See B.5 for a methodology for measuring transmitter device signal output.

### 5.3.6.2 Transmitter device signal output characteristics as measured with the zero-length test load

Table 59 specifies the signal output characteristics for the transmitter device **operating at 1.5 Gbps or 3 Gbps** as measured with the zero-length test load (see 5.3.2.2) attached at a transmitter device compliance point (i.e., IT or CT). All specifications are based on differential measurements. **For 6 Gbps signal output characteristics, see 5.3.6.5.**

**Table 59 — Transmitter device signal output characteristics as measured with the zero-length test load at transmitter device compliance points IT and CT**

Signal characteristic <sup>a</sup>	Units	1.5 Gbps	3 Gbps
Maximum intra-pair skew <sup>b</sup>	ps	20	15
Maximum transmitter device off voltage <sup>c</sup>	mV(P-P)	50	
Maximum rise/fall time <sup>d</sup>	ps	273	137
Minimum rise/fall time <sup>d</sup>	ps	67	
Maximum transmitter output imbalance <sup>e</sup>	%	10	
<del>OOB offset delta<sup>f</sup></del>	<del>mV</del>	<del>±25</del>	
<del>OOB common-mode delta<sup>g</sup></del>	<del>mV</del>	<del>±50</del>	

a All tests in this table shall be performed with zero-length test load (see 5.3.2.2).

b The intra-pair skew measurement shall be made at the midpoint of the transition with a repeating 0101b pattern (see table 218 in 10.2.9.1) on the physical link. The same stable trigger, coherent to the data stream, shall be used for both the Tx+ and Tx- signals. Intra-pair skew is defined as the time difference between the means of the midpoint crossing times of the Tx+ signal and the Tx- signal.

c The transmitter device off voltage is the maximum A.C. voltage measured at compliance points IT and CT when the transmitter is unpowered or transmitting D.C. idle (e.g., during idle time of an OOB signal).

d Rise/fall times are measured from 20 % to 80 % of the transition with a repeating 0101b pattern (see table 218 in 10.2.9.1) on the physical link.

e The maximum difference between the V+ and V- A.C. RMS transmitter device amplitudes measured with CJTPAT (see A.2) into the zero-length test load shown in figure 105 (see 5.3.2.2), as a percentage of the average of the V+ and V- A.C. RMS amplitudes.

~~f The maximum difference in the average differential voltage (D.C. offset) component between the burst times and the idle times of an OOB signal.~~

~~g The maximum difference in the average of the common-mode voltage between the burst times and the idle times of an OOB signal.~~

### 5.3.6.3 Transmitter device signal output characteristics as measured with each test load

Table 60 specifies the signal output characteristics for the transmitter device **operating at 1.5 Gbps or 3 Gbps** as measured with each test load (i.e., the zero-length test load (see 5.3.2.2) and either the TCTF test load (see 5.3.2.3) or the low-loss TCTF test load (see 5.3.2.4)) attached at a transmitter device compliance point (i.e., IT or CT). All specifications are based on differential measurements. **For 6 Gbps signal output characteristics, see 5.3.6.5.**

**Table 60 — Transmitter device signal output characteristics as measured with each test load at transmitter device compliance points IT and CT**

Signal characteristic	Units	IT		CT	
		1.5 Gbps	3 Gbps	1.5 Gbps	3 Gbps
Maximum jitter (see figure 114 in 5.3.5.2) <sup>a</sup>	N/A	See table 63 in 5.3.7.3			
Maximum peak to peak voltage (i.e., 2 x Z2 in figure 114) if SATA is not supported	mV(P-P)	1 600		1 600	
Maximum peak to peak voltage (i.e., 2 x Z2 in figure 114) if SATA is supported	mV(P-P)	see SATA-2 <sup>e</sup>		N/A	
Minimum eye opening (i.e., 2 x Z1 in figure 114), if SATA is not supported	mV(P-P)	325	275	275	
Minimum eye opening (i.e., 2 x Z1 in figure 114), if SATA is supported	mV(P-P)	see SATA-2 <sup>e</sup>		N/A	
Half of maximum jitter (i.e., X1 in figure 114) <sup>b</sup>	UI	0.275			
Center of bit time (i.e., X2 in figure 114)	UI	0,50			
Maximum intra-pair skew <sup>c</sup>	ps	80	75	80	75
Maximum voltage (non-operational)	mV(P-P)	2 000			
<del>Minimum OOB burst amplitude<sup>d</sup>, if SATA is not supported</del>	<del>mV(P-P)</del>	<del>240<sup>f</sup></del>			
<del>Minimum OOB burst amplitude<sup>d</sup>, if SATA is supported</del>	<del>mV(P-P)</del>	<del>240<sup>f</sup></del>		<del>N/A</del>	
<p>a The value for X1 applies at a total jitter probability of 10<sup>-12</sup>. At this level of probability, direct visual comparison between the mask and actual signals is not a valid method for determining compliance with the jitter requirements.</p> <p>b The value for X1 shall be half the value of TJ for maximum delivered jitter listed in table 63. The test or analysis shall include the effects of <b>the JTF (see 5.3.5.1)</b>.</p> <p>c The intra-pair skew measurement shall be made at the midpoint of the transition with a repeating 0101b pattern (see table 218 in 10.2.9.1) on the physical link. The same stable trigger, coherent to the data stream, shall be used for both the Tx+ and Tx- signals. Intra-pair skew is defined as the time difference between the means of the midpoint crossing times of the Tx+ signal and the Tx- signal at the probe points.</p> <p><del>d With a measurement bandwidth of 1.5 times the highest supported baud rate (e.g., 4,5 GHz for 3 Gbps), each signal level during the OOB burst shall exceed the specified minimum differential amplitude before transitioning to the opposite bit value or before termination of the OOB burst.</del></p> <p>e Amplitude measurement methodologies of SATA and this standard differ. Under conditions of maximum rise/fall time and jitter, eye diagram methodologies used in this standard may indicate less signal amplitude than the technique specified by SATA-2. <b>Implementers</b> of designs supporting SATA are required to ensure interoperability and should perform additional system characterization with an eye diagram methodology using SATA devices.</p> <p><del>f The OOB burst contains 1.5 Gbps D24.3 characters or ALIGN (0) primitives (see 6.6 and SATA-2).</del></p>					

#### 5.3.6.4 Transmitter device maximum jitter

Table 61 defines the maximum jitter the transmitter device **operating at 1.5 Gbps or 3 Gbps** shall deliver as measured with each test load (i.e., the zero-length test load (see 5.3.2.2) and either the TCTF test load (see 5.3.2.3) or the low-loss TCTF test load (see 5.3.2.4)) at a transmitter device compliance point (i.e., IT or CT). **For 6 Gbps signal output characteristics, see 5.3.6.5.**

**No changes to Table 61.**

### 5.3.6.5 Transmitter device signal output characteristics for 6 Gbps applications

#### 5.3.6.5.1 Transmitter device signal output characteristics

Table 62 specifies the signal output characteristics for the transmitter device as measured with the zero-length test load (see 5.3.2.2), unless otherwise specified, attached at a transmitter device compliance point (i.e., IT or CT). All specifications are based on differential measurements.

**Table 62 — Transmitter device signal output characteristics for 6 Gbps applications at IT and CT (unless otherwise noted)**

Signal characteristic	Units	Min	Nominal	Max
Peak to peak voltage if SATA is not supported <sup>a</sup>	mV(p-p)	800		1 200
Transmitter device off voltage <sup>b</sup>	mV(p-p)			50
Maximum voltage (non-operational)	mV(p-p)	2 000		
Minimum rise/fall time <sup>c</sup>	UI (ps)	0.25 (41.667)		
Reference Diff Impedance	Ohm		100	
Reference Common Mode Impedance	Ohm		25	
Common mode voltage limit (rms) <sup>d</sup>	dBmV <sup>e</sup>			26
Random Jitter <sup>f</sup>	UI (ps)			0.15 (25)
Half of maximum jitter (i.e., X1 in figure 114) <sup>g, h</sup>	UI (ps)			0.20 (33.333)
Differential eye opening (i.e., 2 x Z1 in figure 114) <sup>g</sup>	mV	tdb		

a See 5.3.6.5.5 for measurement method. Value measured is  $V_{pk-pk}$ .

b The transmitter device off voltage is the maximum A.C. voltage measured at compliance points IT and CT when the transmitter is unpowered or transmitting D.C. idle (e.g., during idle time of an OOB signal).

c Rise/fall times are measured from 20% to 80% of the transition with a repeating 0101b pattern (see table 214 in 10.2.9.1) on the physical link.

d Maximum value at the Nyquist frequency (3 GHz). See Figure 118.

e For dBmV, the reference level of 0 dBmV is 1 mV. Hence, 0 dBm is 1 mW which is 158 mV across 25 ohms (the reference impedance for common mode voltage) which is  $20\log_{10}(158) = +44$  dBmV. +26 dBmV is, therefore, -18 dBm.

f RJ = 14 times the random jitter 1 sigma value, based on a BER of  $10^{-12}$ . Test performed with a repeating 0101b pattern (see table 214 in 10.2.9.1) on the physical link.

g This value is obtained by simulation. It represents and the resulting signal output within the reference receiver (see 5.xxx) after equalization, when the transmitter device output signal of CJTPAT is transmitted through the reference transmitter test load (see 5.3.2.5).

h The value for X1 shall be half the value of TJ for maximum delivered jitter listed in table 63. The test or analysis shall include the effects of the JTF (see 5.3.5.1). **Editor's note: the minimum voltage level for this measurement is 1000 mV pk-pk. How do we specify that here?**

i For transmitter device return loss characteristics, see 5.3.6.5.2.

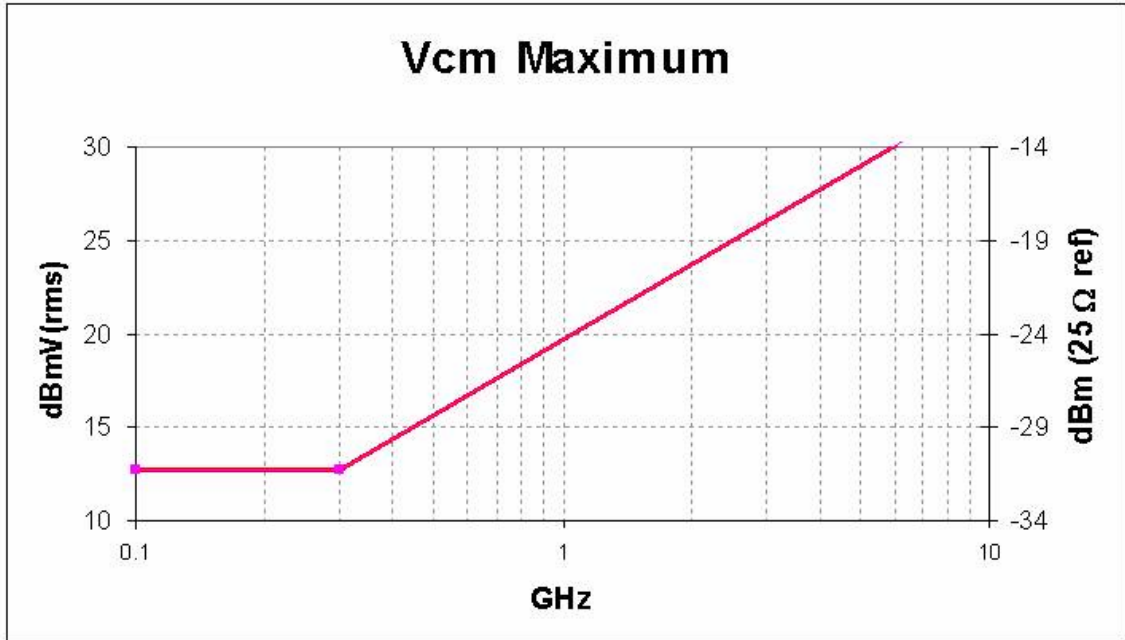


Figure 118 Transmitter device common mode voltage limit

### 5.3.6.5.2 Transmitter device return loss

Return loss limits shall be calculated per the following formula. Variables are illustrated in Figure 119 and specified in Table 63.

$$\text{Measured Value} < \max [ L, \min [ H, N + 13.3 \log_{10}(F/3\text{GHz}) ] ]$$

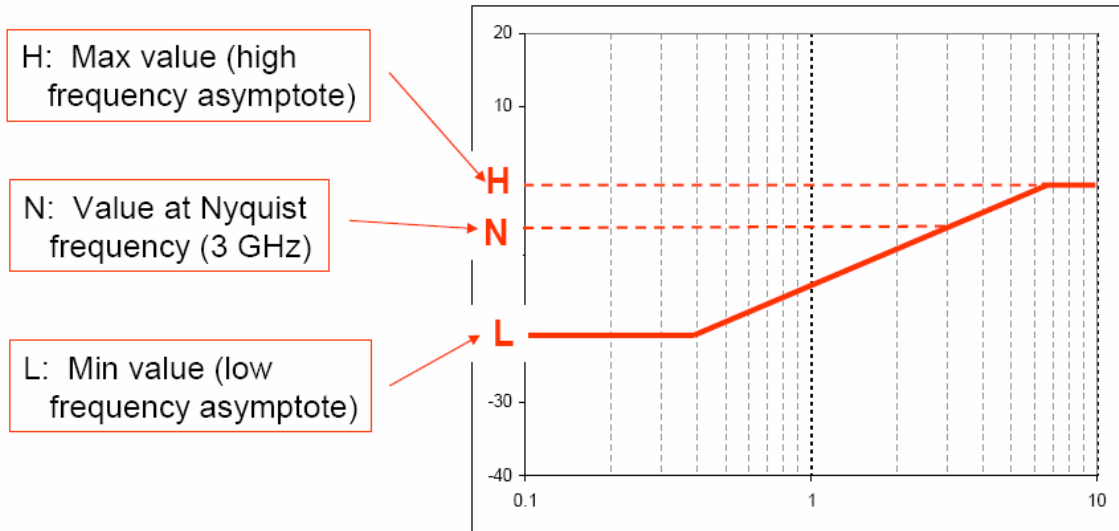


Figure 119 Return loss variables

Table 63 — Return loss at the transmitter device compliance point (i.e., IT or CT)

	Figure	L(dB)	N(dB)	H(dB)	S(dB)	F <sub>Min</sub> (MHz)	F <sub>Max</sub> (GHz)
SCC22 common mode return loss	120	-6.0	-5.0	0	13.3	100	6.0
SDD22 differential return loss	120	-10	-7.9	0	13.3	100	6.0
SCD22 differential to common mode conversion	121	-26	-12.7	-10	13.3	100	6.0

Notes:

1. For return loss measurements, the transmitter under test shall transmit a continuous D24.3 pattern. The amplitude shall be -4.4 dBm (190mV zero to peak) maximum per port. See section B.9.3.
2. The return loss numbers indicate the value on the transmitter side of the compliance point connector rather than at the compliance point (i.e., IT or CT)



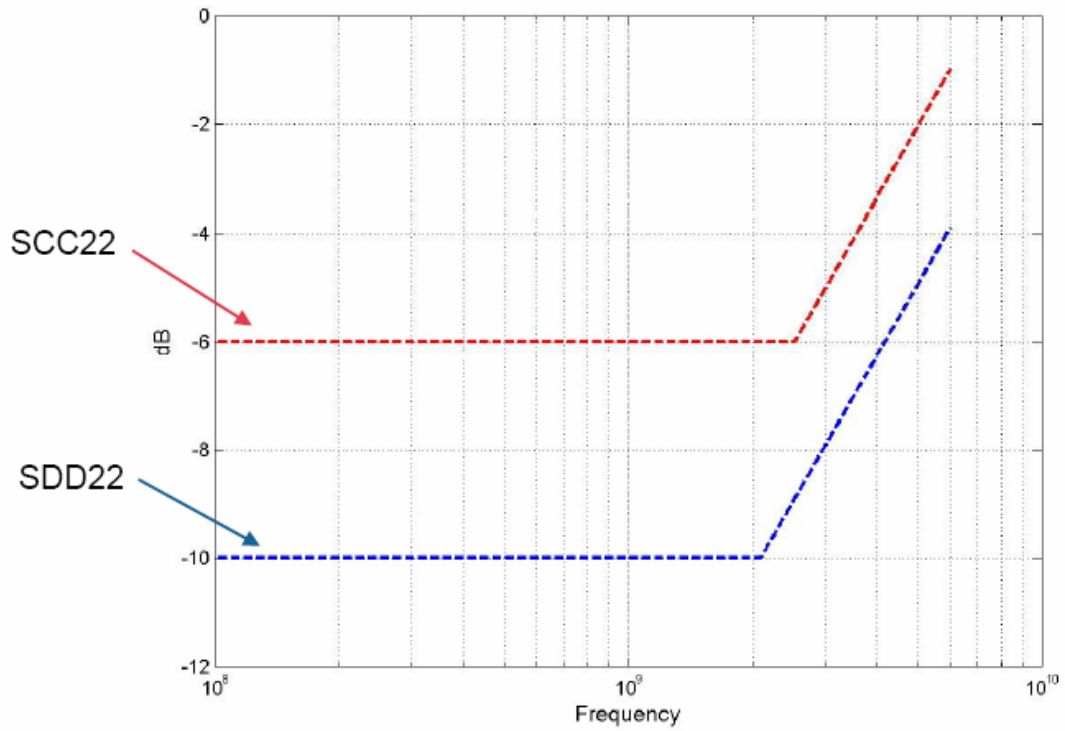


Figure 120 Transmitter Differential and Common Mode Return Loss

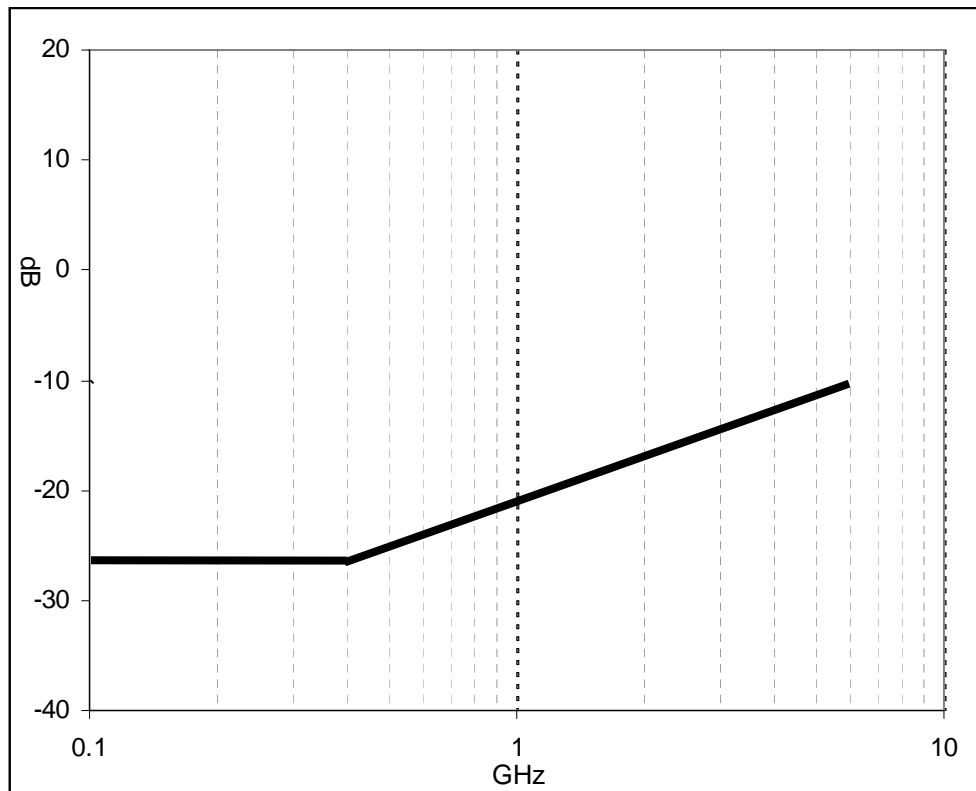


Figure 121 SCD22 Differential to Common Mode Conversion

### 5.3.6.5.3 Recommended transmitter device settings for interoperability.

The settings in Table 64 are recommended values for transmitter devices to provide interoperability with a broad range of applications utilizing compliant TxRx connections and compliant receiver devices. The values are based on the evaluation of simulations with a variety of characterized physical hardware. Use of the recommended values does not guarantee that an implementation is capable of achieving a specific BER.

Specific applications may obtain increased margin by deviating from the recommended values, however, such implementations are beyond the scope of this specification.

**Table 64 — Recommended transmitter device settings for interoperability**

Transmitter device	Units	Min	Nominal	Max
Differential Voltage Swing (mode) $V_{vma}$ <sup>1</sup>	mV	600	707	
Tx Equalization <sup>1</sup>	dB	2	3	4
Notes:				
1. See 5.3.6.5.5 for measurement method.				

### 5.3.6.5.4 Reference transmitter device characteristics

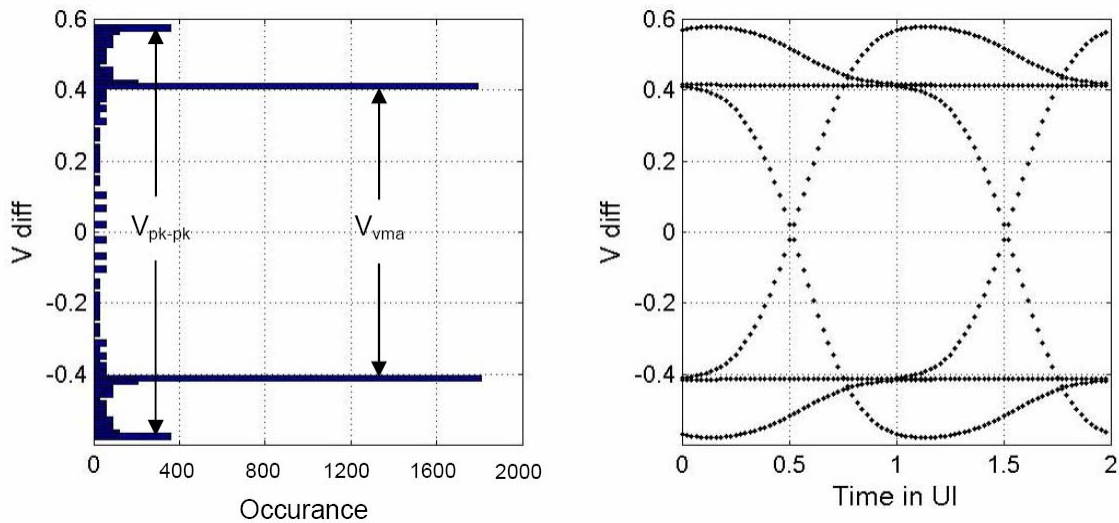
The reference transmitter device is a set of parameters defining the electrical performance characteristics of a transmitter device to be used in mathematical modeling to determine compliance of the TxRx connection. The return loss characteristics of the reference transmitter device are represented by files that may be obtained under proposal number 07-267, 6G SAS Reference TX & RX Termination Networks.

**Table 65 — Reference transmitter device characteristics**

Transmitter device	Value	Units
Peak to peak voltage <sup>a</sup>	1 000 <sup>c</sup>	mV(p-p)
Tx Equalization <sup>a</sup>	2	dB
Maximum rise time <sup>b</sup>	0.41 (68.333)	UI (ps)
Random Jitter	0.15 (25)	UI (ps)
Deterministic Jitter	0.15 (25)	UI (ps)
<p>a See 5.3.6.5.5 for measurement method. Value measured is <math>V_{pk-pk}</math>.</p> <p>b Rise/fall times are measured from 20 % to 80 % of the transition with a repeating 0101b pattern (see table 214 in 10.2.9.1) on the physical link.</p> <p>c This voltage reflects a higher value than the minimum required transmitter voltage.</p>		

### 5.3.6.5.5 Transmitter device equalization measurement

- a The equalization measurement shall be based on a mode measurement for  $V_{vma}$  and a peak-to-peak measurement for  $V_{pk-pk}$  using a TWO\_DWORDS phy test pattern of D30.3 (see Table 215 in 10.2.9.1). If the phy test function is not supported, a vendor-specific method may be used to produce this pattern.
- b The voltage measurements shall be made with the transmitter device terminated through the interoperability point into a Zero Length Test Load.
- c The  $V_{pk-pk}$  and  $V_{vma}$  values shall be measured using the following or an equivalent procedure:
  - a. An equivalent time sampling scope with a histogram function shall be used.
  - b. The sampling scope shall be calibrated for measurement of a 3GHz signal.
  - c. The  $V_{vma}$  mode value and  $V_{pk-pk}$  peak value shall be determined as illustrated in Figure xxx. A sample size of 1000 minimum, 2000 maximum histogram hits for  $V_{vma}$  shall be used to determine the values. The histogram in the figure is a combination of two histograms, an upper histogram for TX+ and lower histogram for TX-. (The histograms on the left of the test pattern signal displayed on the right.) The  $V_{vma}$  mode value and  $V_{pk-pk}$  peak value are determined by adding the values measured for TX+ and TX-.



**Figure xxx Transmitter equalization measurement**

- d The following formula shall be used to calculate the equalization value:

$$DE_{dB} = 20 \text{Log}_{10} \left( \frac{V_{pk-pk}}{V_{vma}} \right)$$

### 5.3.6.6 Transmitter device signal output levels for OOB signals

Transmitter devices supporting SATA shall use SATA Gen1i or Gen2i signal output levels (see SATA-2) during the first OOB sequence (see 6.7) after a power on or hard reset. If the phy does not receive COMINIT within a hot-plug timeout (see 6.7.5), the transmitter device shall increase its transmit levels to the SAS signal output levels specified in table 66 59 (see 5.3.6) and table 60 (see 5.3.6.3) and perform the OOB sequence again. If no COMINIT is received within a hot-plug timeout of the second OOB sequence, the transmitter device shall initiate another OOB sequence using SATA Gen1i or Gen2i signal output levels. The transmitter device shall continue alternating between transmitting COMINIT using SATA Gen1i or Gen2i signal output levels and transmitting COMINIT with SAS signal output levels until the phy receives COMINIT.

If the phy both transmits and receives COMSAS (i.e., a SAS phy or expander phy is attached), the transmitter device shall set its transmit levels to the SAS signal output levels prior to beginning the SAS speed negotiation sequence (see 6.7.4.2). If it had been using SATA Gen1i or Gen2i signal output levels, this mode transition (i.e., output voltage change) may result in a transient (see 5.3.4) during the idle time between COMSAS and the SAS speed negotiation sequence (see 6.7.4.2).

If the transmitter device is using SAS signal output levels and the phy does not receive COMSAS (i.e., a SATA phy is attached), the transmitter device shall set its transmit levels to the SATA Gen1i or Gen2i signal output levels and restart the OOB sequence.

Transmitter devices that do not support SATA shall transmit OOB signals using SAS signal output levels.

~~Editor's Note 20: mention that the selected signal output level is used for the speed negotiation sequence and beyond~~

**Table 66 — OOB electrical characteristics**

Characteristic	Units	IT	CT
Maximum peak to peak voltage (i.e., 2 x Z2 in figure 114) <sup>a</sup>	mV(P-P)	1 600	
OOB offset delta <sup>b</sup>	mV	±25	
OOB common mode delta <sup>c</sup>	mV	±50	
Minimum OOB burst amplitude <sup>d</sup> , if SATA is not supported	mV(P-P)	240 <sup>f</sup>	
Minimum OOB burst amplitude <sup>d</sup> , if SATA is supported	mV(P-P)	240 <sup>e,1</sup>	N/A
<p>a The recommended maximum peak to peak voltage is 1 200 mV(P-P).</p> <p>b The maximum difference in the average differential voltage (D.C. offset) component between the burst times and the idle times of an OOB signal.</p> <p>c The maximum difference in the average of the common-mode voltage between the burst times and the idle times of an OOB signal.</p> <p>d With a measurement bandwidth of 4.5 GHz, each signal level during the OOB burst shall exceed the specified minimum differential amplitude before transitioning to the opposite bit value or before termination of the OOB burst.</p> <p>e Amplitude measurement methodologies of SATA and this standard differ. Under conditions of maximum rise/fall time and jitter, eye diagram methodologies used in this standard may indicate less signal amplitude than the technique specified by SATA-2. Implementers of designs supporting SATA are required to ensure interoperability and should perform additional system characterization with an eye diagram methodology using SATA devices.</p> <p>f The OOB burst contains 1.5 Gbps D24.3 characters or ALIGN (0) primitives (see 6.6 and SATA-2).</p>			

**Receiver:**

<b>Receiver device</b>	Min	Nominal	Max	Units
SDD11 Differential Return Loss			See Figure xyx	dB
SCC11 Common Mode Return Loss			See Figure xyx	dB
Reference Diff Impedance		100		Ohm
Reference Common Mode Impedance		25		Ohm
Common Mode Tolerance (2-200MHz)	150			mV
Max Operational Differential Input Voltage (pk-pk) @ 6 Gbps	1 200			mV
Max Operational Differential Input Voltage (pk-pk) @ 1.5 and 3 Gbps	1 600			mV
Max Non-Operational Input Voltage(pk-pk)	2 000			mV

**Table 60 — Receiver device jitter tolerance at receiver device compliance points IR and CR**  
**Mike Jenkins to update for 6Gbps**

Signal Characteristic	Units	IR			CR		
		1.5 Gbps	3 Gbps	6 Gbps	1.5 Gbps	3 Gbps	6 Gbps
Applied sinusoidal jitter (SJ) <sup>b</sup>	UI	0,10 <sup>c</sup>	0,10 <sup>d</sup>	0,10 <sup>i</sup>	0,10 <sup>c</sup>	0,10 <sup>d</sup>	0,10 <sup>i</sup>
Deterministic jitter (DJ) <sup>a, h</sup>	UI	0,35 <sup>f</sup>	0,35 <sup>g</sup>	0,35 <sup>j</sup>	0,35 <sup>f</sup>	0,35 <sup>g</sup>	0,35 <sup>j</sup>
Total jitter (TJ) <sup>a, e, h, k</sup>	UI	0,65					

a All DJ and TJ values are level 1 (see MJSQ).  
 b The jitter values given are normative for a combination of applied SJ, DJ, and TJ that receiver devices shall be able to tolerate without exceeding the required BER (see 5.3.3). Receiver devices shall tolerate applied SJ of progressively greater amplitude at lower frequencies, according to figure 116 (see 5.3.5.4), with the same DJ and RJ levels as were used in the high frequency sweep.  
 c Applied sinusoidal swept frequency: 900 kHz to the minimum of 5 MHz and (3,75 x 2<sup>(generation - 1)</sup> MHz) (e.g., 5 MHz for 1.5 Gbps and 7,5 MHz for 3 Gbps).  
 d Applied sinusoidal swept frequency: 1 800 kHz to the minimum of 5 MHz and (3,75 x 2<sup>(generation - 1)</sup> MHz) (e.g., 5 MHz for 1.5 Gbps and 7,5 MHz for 3 Gbps).  
 e No value is given for RJ. For compliance with this standard, the actual RJ amplitude shall be the value that brings TJ to the stated value at a probability of 10<sup>-12</sup>. The additional 0,1 UI of applied SJ is added to ensure the receiver device has sufficient operating margin in the presence of external interference.  
 f The measurement bandwidth shall be 900 kHz to 750 MHz.  
 g The measurement bandwidth shall be 1 800 kHz to 1 500 MHz.  
 h The DJ and TJ values in this table apply to jitter measured as described in 5.3.5.3. Values for DJ and TJ shall be calculated from the CDF for the jitter population using the calculation of level 1 jitter compliance levels method in MJSQ.  
 i Applied sinusoidal swept frequency: 3 600 kHz to 15 MHz.  
 j The measurement bandwidth shall be 3 600 kHz to 3 000 MHz.  
 k TJ for 6 Gbps is after equalization and not at the compliance point.

Performance of the receiver device shall be equal to or better than the reference receiver. OOB detection shall be as specified for 1.5 and 3 Gbps devices. For jitter tolerance, see Table 60.

**Reference Receiver**

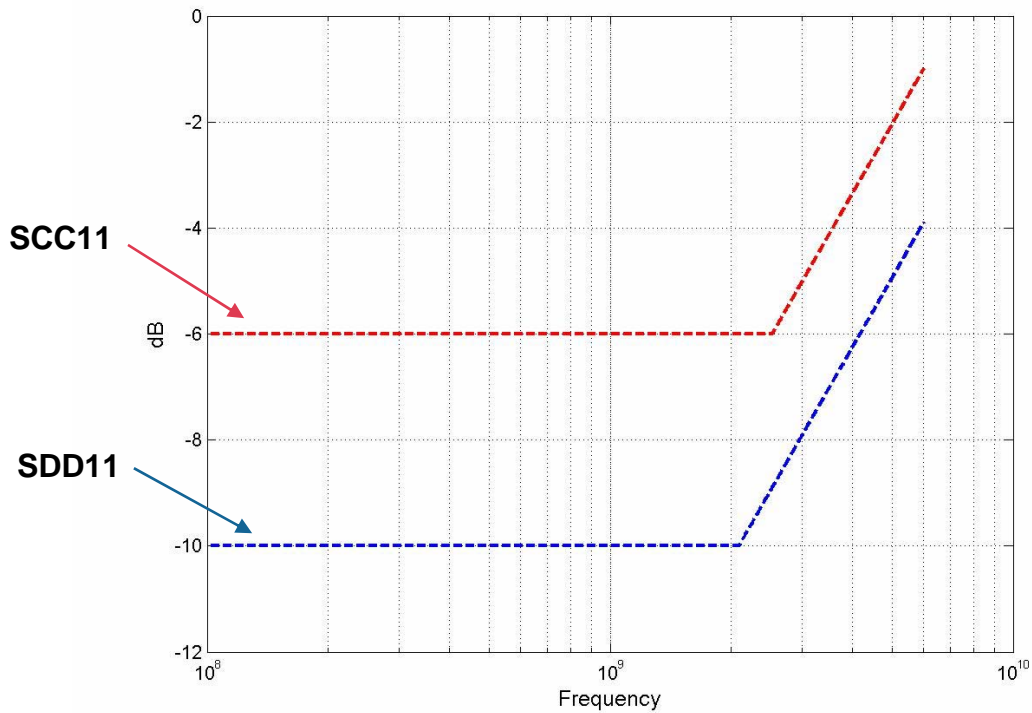
The receiver's return loss is illustrated in Figure xyx. (Need pointer to reference termination file.) The reference receiver has a 3 tap DFE with infinite precision taps and unit interval tap spacing. The reference coefficient adaptation algorithm is the Least Mean Squared (LMS). The DFE equalizer can be modeled at the center of the eye as:

$$y_k = x_k - \sum_{i=1}^2 d_i x_{k-i}$$

The reference receiver assumes the coefficients ( $d_i$ ) are positive and their magnitudes are less than  $\frac{1}{2}$ .

The simulated steady-state equalizer inter-eye opening for a complaint link shall be 100mV vertical and 0.6 UI horizontal at a BER of  $1e-15$  with the appropriate noise, jitter and crosstalk sources.

Additional reference information may be found in: Lee, Edward A., Messerschmitt, David G., "Digital Communication," Boston, Kluwer Academic Publishers, 1994



**Figure xyx Receiver Differential and Common Mode Return Loss**

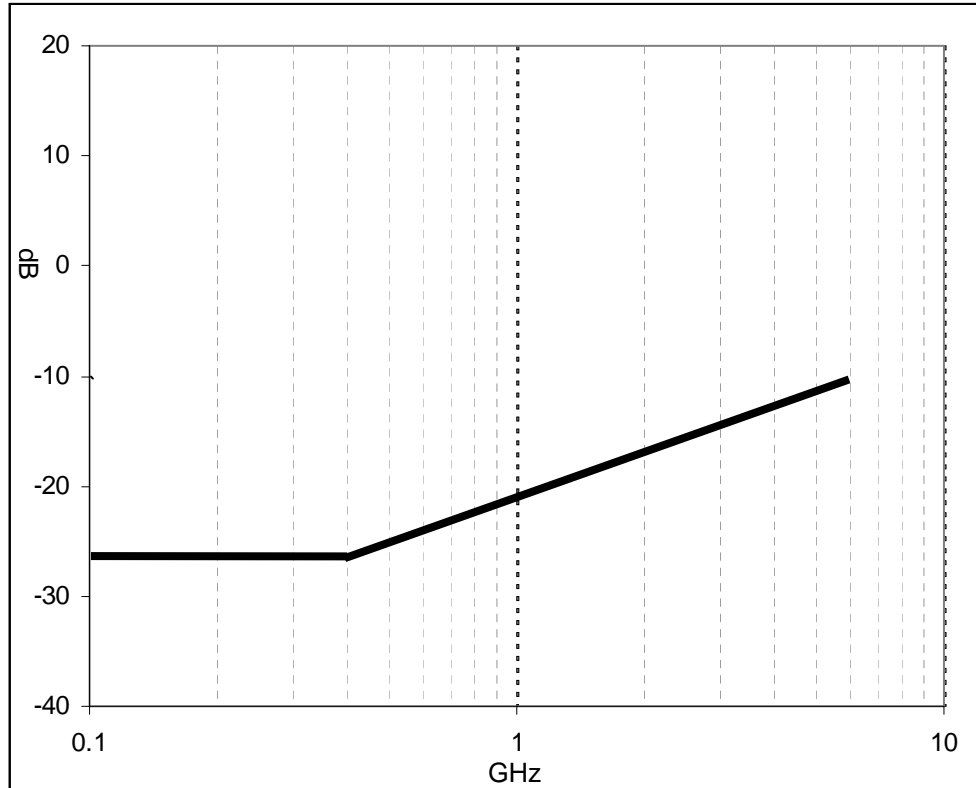
Return loss limits shall be calculated per the following formula. Variables are illustrated in Figure xxw and specified in Table 5.

$$\text{Measured Value} < \max [ L, \min [ H, N + 13.3 \log_{10}(F/3\text{GHz}) ] ]$$

	Figure	L(dB)	N(dB)	H(dB)	S(dB)	F <sub>Min</sub> (MHz)	F <sub>Max</sub> (GHz)
SCC11 common mode return loss	xyx	-6,0	-5,0	0	13,3	100	6,0
SDD11 differential return loss	xyx	-10	-7,9	0	13,3	100	6,0
SCD11 differential to common mode conversion	xyy	-26	-12,7	-10	13,3	100	6,0
Notes:							
1. For return loss measurements, the transmitter shall transmit a continuous D24.3 pattern. The amplitude shall be -4,4 dBm (190mV zero to peak) maximum per port. See section B.9.3.							

**Table 5 Return loss at the receiver device compliance point**





**Figure xxz SCD11 Differential to Common Mode Conversion**

A SAS-2 receiver device has the electrical characteristics illustrated in Table xx

**Informative receiver physical test:**

The TxRx connection should consist of 10-meter Mini SAS 4x cable with s-parameter characteristics similar to those of the reference channel (07-193).

Apply an 800mV pk-pk signal from a compliant transmitter.

Jitter should be applied at the transmitter end.

SSC should be enabled. The SSC profile should be the same as that applied to the receiver device during normal operation. Multiple tests may be required depending on if the receiver device supports connection to SATA, center-spreading transmitter devices, or downspreading transmitter devices.

NEXT should be actively applied at the receiver end.

The receiver should perform data recovery at  $10e-12$  with 95% confidence level (assuming Poisson distribution). The table below indicates the minimum number of bits required to be received versus the number of bit errors detected to achieve a 95% confidence level of  $10^{-12}$  BER performance.

	95% confidence level of $10^{-12}$ BER					
Number of errors	0	1	2	3	4	5
Number of bits	$3.00 \times 10^{12}$	$4.74 \times 10^{12}$	$6.30 \times 10^{12}$	$7.75 \times 10^{12}$	$9.15 \times 10^{12}$	$1.05 \times 10^{13}$

## B.1 Signal performance measurements overview

This annex specifies the configuration requirements for making electrical performance measurements. These measurements consist of signal output, signal tolerance, and return loss. Standard loads are used in all cases so that independent specification of connection components and transportability of the measurement results are possible.

~~NOTE 106—The methodology for making return loss measurements are specified in this annex although this standard does not define any return loss values. Statements in this annex that imply return loss values are specified should be ignored.~~

### B.2.3 Definition of receiver sensitivity and receiver device sensitivity

~~For 1.5Gbps and 3 Gbps, receiver~~ device sensitivity is defined as the minimum vertical inner eye opening measured at the signal output point for the input to the receiver device at which the receiver chip (i.e., the receiver circuit in the chip package on the board containing the receiver device interoperability point as shown in figure B.3) delivers the required BER (see 5.3.3) with:

- ~~ha)~~ the minimum horizontal eye opening;
- ~~ab)~~ all activity expected in the application for the receiver circuit present (i.e., not quiesced as for the receiver sensitivity definition); and
- ~~bc)~~ the CJTPAT pattern being received (see Annex A).

~~For 6Gbps receiver devices, the eye opening above is determined by simulation. The signal measured at the input to the receiver device is processed in a manner to simulate the additional interconnect losses (i.e., board traces, IC package, etc) and then the equalization function provided by the receiver circuit is applied to determine the resulting eye opening. Special test conditions are required to measure these sensitivities (see B.8). The terminology used in this standard is signal tolerance instead of receiver device sensitivity.~~

### B.9.3 Use of single-ended instrumentation in differential applications

There are four categories of S-parameters for a differential system:

- a) SDDij: differential stimulus, differential response;
- b) SCDij: differential stimulus, common-mode response (i.e., mode conversion causing emissions);
- c) SDCij: common-mode stimulus, differential response (i.e., mode conversion causing susceptibility); and
- d) SCCij: common-mode stimulus, common-mode response.

~~All the measurements specified in this standard relate to differential signal pairs, and all specified S-parameters are of the SDDij form.~~

Figure B.13 shows the connections that are made to a four port VNA or TDNA for measuring S-parameters on a four single-ended port black box device.

VNA ports are all single-ended; the differential and common-mode properties for differential ports are calculated internal to the VNA or may mathematically derived. If using a TDNA, consult the details for the specific instrument. Four analyzer ports are required to measure the properties of two differential ports.

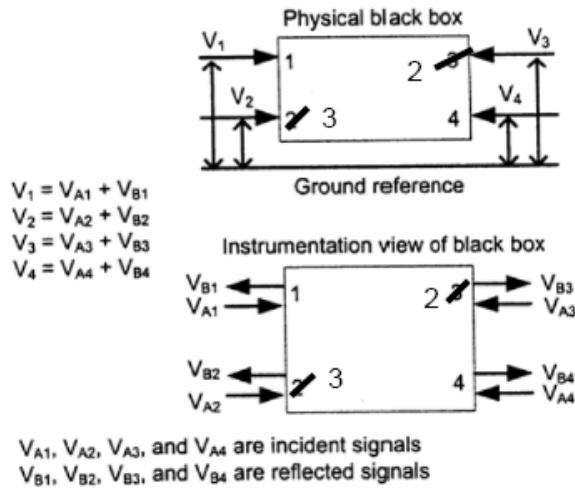


Figure B.13 — Four single-ended port or two differential port element

Figure B.14 shows the set of S-parameters for a single-ended system and for a differential system.

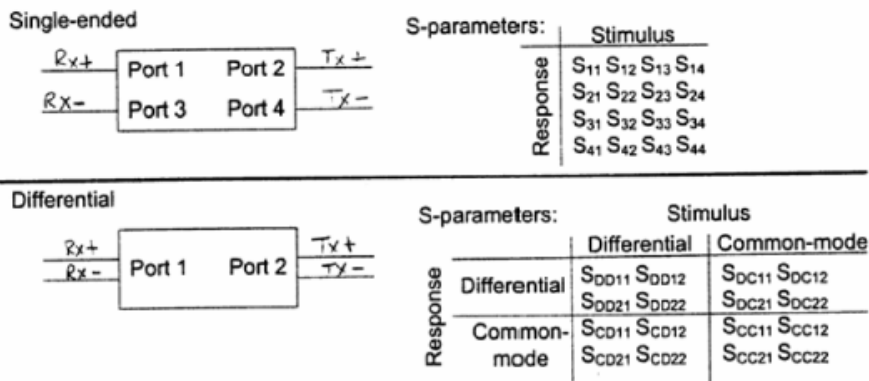


Figure B.14 — S-parameters for single-ended and differential systems

$$S_{mm} = \frac{1}{2} \begin{array}{cc} \begin{array}{c} \text{SDD11} \\ \left( \begin{array}{c} S_{11} - S_{13} - S_{31} + S_{33} \\ S_{21} - S_{23} - S_{41} + S_{43} \\ S_{11} - S_{13} + S_{31} - S_{33} \\ S_{21} - S_{23} + S_{41} - S_{43} \end{array} \right) & \begin{array}{c} S_{12} - S_{14} - S_{32} + S_{34} \\ S_{22} - S_{24} - S_{42} + S_{44} \\ S_{12} - S_{14} + S_{32} - S_{34} \\ S_{22} - S_{24} + S_{42} - S_{44} \end{array} \\ \text{SCD11} \end{array} & \begin{array}{c} \text{SDC11} \\ \left( \begin{array}{c} S_{11} + S_{13} - S_{31} - S_{33} \\ S_{21} + S_{23} - S_{41} - S_{43} \\ S_{11} + S_{13} + S_{31} + S_{33} \\ S_{21} + S_{23} + S_{41} + S_{43} \end{array} \right) & \begin{array}{c} S_{12} + S_{14} - S_{32} - S_{34} \\ S_{22} + S_{24} - S_{42} - S_{44} \\ S_{12} + S_{14} + S_{32} + S_{34} \\ S_{22} + S_{24} + S_{42} + S_{44} \end{array} \\ \text{SCC11} \end{array} \end{array}$$